

目录 CONTENT

SGP1 齿轮油泵	1
SGP1 gear oil pump	
SGP2 齿轮油泵	4
SGP2 gear oil pump	
KZP4 系列齿轮泵	7
KZP4 series gear pump	
DSG06 低噪音齿轮油泵	9
DSG06 gear oil pump of lower noise	
C101/102 自卸车齿轮泵	10
C101 /102 dump truck gear pump	
KP1505A 自卸车举升泵	11
KP1505A dump truck lifting gear pump	
KP1405A 自卸车举升泵	12
KP1405A dump truck lifting gear pump	
KP1403A 自卸车举升泵	13
KP1403A dump truck lifting gear pump	
KP1405A-R 自卸车举升泵	14
KP1405A -R dump truck lifting gear pump	
KP1403A-R 自卸车举升泵	15
KP1403A -R dump truck lifting gear pump	
KPA-1302B 自卸车举升泵	16
KPA -1302B dump truck lifting gear pump	
KP75A 自卸车举升泵	17
KP75A dump truck lifting gear pump	
KP75B 自卸车举升泵	18
KP75B dump truck lifting gear pump	
KP75S 自卸车举升泵	19
KP75S dump truck lifting gear pump	
KP55 自卸车举升泵	20
KP55 dump truck lifting gear pump	
GPG55 自卸车举升泵	21
GPG55 dump truck lifting gear pump	
KP35B 自卸车举升泵	22
KP35B dump truck lifting gear pump	



Dongguan Blnce Machinery & Electronics Co., Ltd

SGP1 齿轮油泵 SGP1 gear oil pumps

一、概述

SGP1系列齿轮泵是一种环保型产品，它除了具备原有齿轮油泵的特点外，更具有噪音低、体积小、安装方便的特点。已被起重搬运机械、筑路机械、环保机械、轻工机械等行业广泛采用，成为各类环保型主机的首选配备。

SGP1 series gear pumps are environmental friendly products with the features of low noise, smart structure and easy installation. The pumps are widely applied in the industries of hoisting and conveying machinery, road machinery, environmental protection machinery, light industry machinery, etc. The pump has been the first option accessory parts for variety of environmental friendly main equipment.

二、外形图

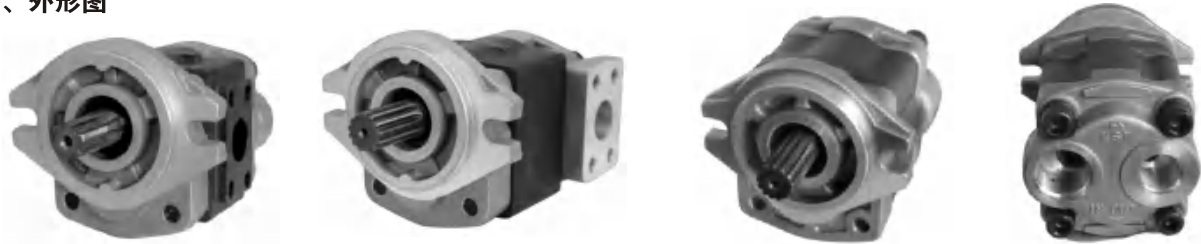

三、型号说明 Model descriptions

SGP1 — 32 D S H 1— L ***
 ① ② ③ ④ ⑤ ⑥ ⑦ ⑧ ⑨

- ①SGP1 Series
- ②法兰止口尺寸 Mounting spigot diameter
 —: $\Phi 82_{-0.086}^{-0.051}$ A: $\Phi 82.55_{-0.05}^0$
 C: $\Phi 80_{-0.046}^0$ B: $\Phi 85_{-0.09}^{-0.036}$
- ③公称排量 (毫升/转)
 Nominal displacement (mL/r)
 19、23、25、27、30、32、36
- ④油口位置 Position of ports
 D.后面油口 Rear port
 F.侧面油口 (在后盖上) Side port (on cover rear)
 A.侧面油口 (在泵体上) Side port (on body)
- ⑤油口形式 Port configuration
 1.SAE法兰油口 (只用于侧面)
 SAE flange port (side only)
 进油口 Inlet: $\Phi 25$; 52.4*26.2; 4-M10*1.25
 出油口 Outlet: $\Phi 20$; 47.6*22.2; 4-M10*1.25
 2.G螺纹 (JISB2351) 同PF螺纹
 G screw thread (JISB2351) same as PF
 进油口 Inlet: G1
 出油口 Outlet: G1/2、G3/4
- 3.UNF螺纹 UNF screw thread
 S: 进油口 Inlet M27*2 出油口 Outlet M22*15
 S1: (A型油口适用30以上排量)
 S1 (A type port apply to the displacement of 30、32、36)
 进油口 Inlet: M33*2 出油口 Outlet: M27*2
- 9.特殊 Special
- ⑥安装方式 Mounting
 H:水平方向2个螺栓中心距 Horizontal 2 bolts:106
 H1:水平方向2个螺栓中心距 Horizontal 2 bolts:130
- ⑦轴伸方式 Shaft type
 1.SAE花键 SAE spline: 16/32DP, 齿数 Teeth No.: 13, 长 Length:42
 2.平键圆柱 (轴伸直径 $\Phi 20$) Straight spline (dia. $\Phi 20$)
 5.SAE花键 SAE spline: 16/32DP, 齿数 Teeth No.:10, 长 Length:33
 H.矩形花键 Rectangle spline: 6-20*16*4, 长 Length: 70
 H1. 矩形花键 Rectangle spline: 6-20*16*4, 长 Length: 41.5
- 9.特殊 Special
- ⑧旋转方向 (轴端看) Direction of rotation (from shaft end)
 L:左旋 (逆时针) Left rotation (counterclockwise)
 R:右旋 (顺时针) Right rotation (clockwise)
- ⑨设计序号 Code number

四、性能参数 Performance parameters

型号 Models	公称排量 Nominal displacement (mL/r)	压力 Pressure (Mpa)		转速 Rotation speed (r/min)			容积效率 Volumetric Efficiency (≤%)	L	重量 Weight (kg)
		额定 Rated	最高 Max	最低 Min	额定 Rated	最高 Max			
SGP1-19	19	20	25	600	2500	3000	92	115.5	4.1
SGP1-23	23							118.5	4.3
SGP1-25	25							122.5	4.6
SGP1-27	27							124.5	4.8
SGP1-30	30							126.5	5.0
SGP1-32	32							131.5	5.4
SGP1-36	36							130.5	5.8

SGP1 齿轮油泵 SGP1 gear oil pumps

D型油口 Oil Port in Styl D

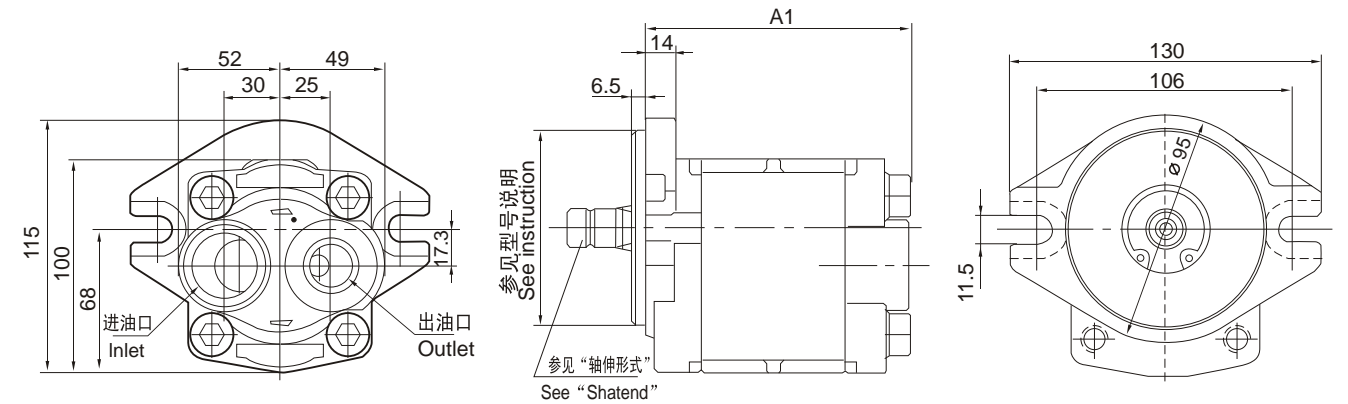

后面油口 (Rear Port)

排量 Displacement	23	25	27	30	32	36
A1	117	118	122	124	128	132

A型油口 Oil Port in Styl A

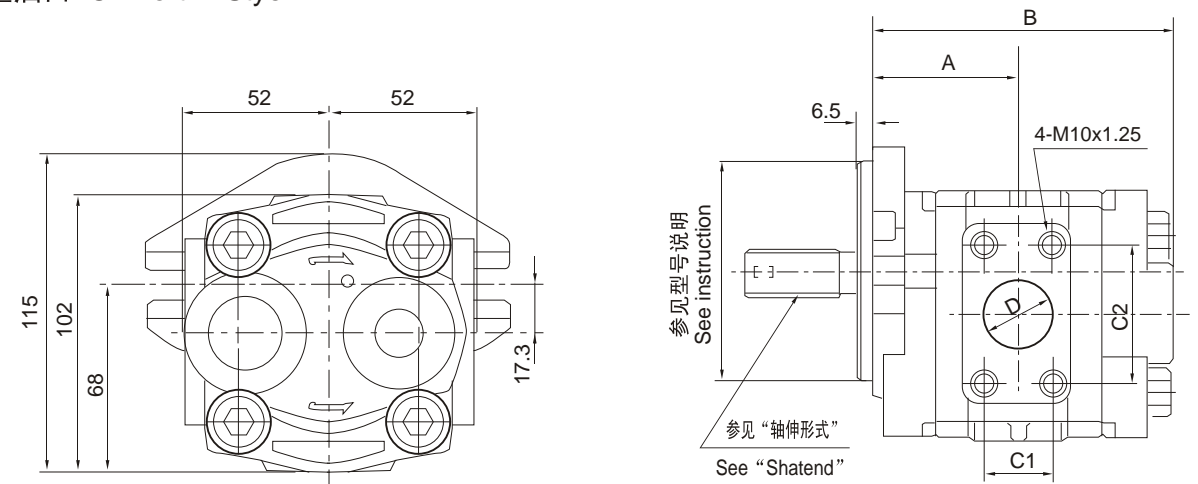

侧面油口 (Side Port)

排量 Displacement	A	B	进油口 Inlet port			出油口 outlet port		
			C1	C2	D	C1	C2	D
30	64.3	124	26.2	52.4	25	22.2	47.6	20
32	66.3	128						
36	68.3	132						

SGP1 齿轮油泵 SGP1 gear oil pumps

F型油口 Oil Port in Styl F

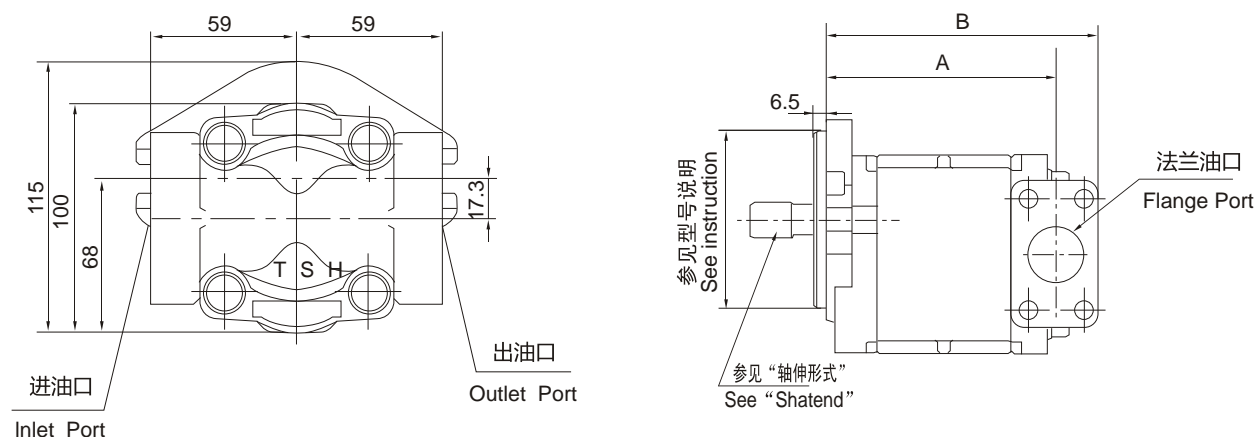

排量 Displacement	A	B
23	107.0	130.5
25	108.5	132
27	112.0	135.5
30	114.5	138
32	118.5	142.0
36	122.5	146.0

1: SAE标准

齿数 No. of tooth 13
D. P. 16/32
压力角 Pressure angle 30°
C. P. O. 1963”
外径 Over pin ida
ø 21.80
ø 21.68
齿底径 Pin dia. ø 18.63

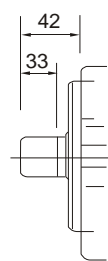

5: SAE标准

齿数 No. of tooth 10
D. P. 16/32
压力角 Pressure angle 30°
C. P. O. 1963”
外径 Over pin ida
ø 17.043
ø 16.916
齿底径 Pin dia. ø 13.86

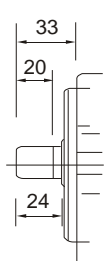

2: 平键 Straight Spline

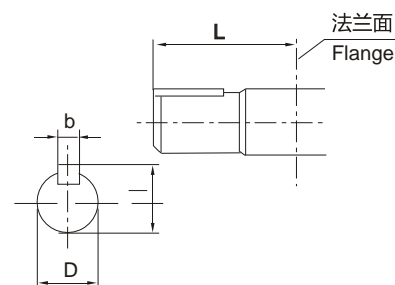

H, H1: 矩形花键

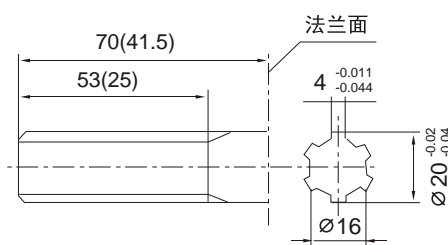

()内尺寸为H1号轴伸尺寸

轴伸形式 Shaft end	D	b	I	L
2号平键 Straight spline NO.2	20	6	22.5	42

SGP2 齿轮油泵 SGP2 gear oil pumps

一、概述

SGP2系列齿轮泵是具有轴向间隙自动补偿和径向液压平衡的外啮合齿轮泵，采用三开式结构；轴承采用DU轴承；侧板为双金属材料；前盖，后盖为高强度铝合金件；中间体为铸铁件，表面镀有金属陶瓷。从而有效地提高齿轮泵的性能指标、寿命及可靠性。

SGP2A series gear pump is external gear pump possessing axial clearance automatic compensation and radial hydraulic balance, adopting three opening structure. The bearings are DU bearings and the side plate is bimetallic material. The front and rear covers, are made of aluminum accessory with high strength. The middle part is consist of iron casting and the surface is covered with metal ceramic. All above improve the performance, lifetime and reliability of the pump.

二、外形图



三、型号说明 Model descriptions

SGP2 — 36 D 1 H 1— L ***
① ② ③ ④ ⑤ ⑥ ⑦ ⑧ ⑨

①SGP2 Series

②法兰止口尺寸 Mounting spigot diameter

—: $\Phi 82^{+0.036}_{-0.090}$ Z: $\Phi 102^{+0.036}_{-0.090}$
A: $\Phi 82.55^{0}_{-0.05}$ B: $\Phi 101.6^{0}_{-0.05}$

③公称排量 (毫升/转)

Nominal displacement (mL/r)
20.23.25.27.32.36.40.44.48.52

④油口位置 Position of ports

D. 后面油口 Rear port
F. 侧面油口 (在后盖上) Side port (on cover rear)
A. 侧面油口 (在泵体上) Side port (on body)

⑤油口形式 Port configuration

1. SAE法兰油口 (只适用于36以下排量)
SAE flange port (only for the displacement below 36mL/r)
进油口 Inlet: $\Phi 25$; 52.4*26.2; 4-M10*1.25
出油口 Outlet: $\Phi 20$; 47.6*22.2; 4-M10*1.25

2. G螺纹 (JISB2351) 同PF螺纹

G screw thread (JISB2351) same as PF
进油口 Inlet: G1 出油口 Outlet: G3/4

3. W螺纹 W screw thread

9. 特殊 Special

⑥安装方式 Mounting

H: 水平方向2个螺栓中心距 Horizontal 2 bolts: 106
H1: 水平方向2个螺栓中心距 Horizontal 2 bolts: 130

⑦轴伸方式 Shaft type

1. SAE花键 SAE spline: 16/32DP, 齿数 Teeth No.: 13, 长 Length: 42
2. 平键圆柱 (轴伸直径 $\Phi 20$) Straight spline (dia. $\Phi 20$)
9. 特殊 Special

⑧旋转方向 (轴端看) Direction of rotation (from shaft end)

L: 左旋 (逆时针) Left rotation (counterclockwise)
R: 右旋 (顺时针) Right rotation (clockwise)

⑨设计序号 Code number

四、性能参数 Performance parameters

型号 Models	公称排量 Nominal displacement (mL/r)	压力 Pressure (Mpa)		转速 Rotation speed (r/min)		进油口压力 Inlet pressure Mpa	重量 Weight (kg)		
		额定 Rated	最高 Max	最低 Min	最高 Max				
SGP2-20	20	24.5	29.4	400	3000	-0.02~0.2	4.9(4.4)		
SGP2-23	23						5.1(4.6)		
SGP2-25	25						5.3(4.8)		
SGP2-27	27						5.4(4.9)		
SGP2-32	32						5.7(5.1)		
SGP2-36	36						5.9(5.3)		
SGP2-40	40	22.6	27.5	400	3000(2500)	-0.02~0.2	6.1(5.4)		
SGP2-44	44	20.6	24.5				6.3(5.6)		
SGP2-48	48	18.6	22.6				6.6 (5.9)		
SGP2-52	52	17.2	20.6				6.8 (6.1)		

SGP2 齿轮油泵 SGP2 gear oil pumps

五、外形尺寸图

SGP2-XXF1HX-LXXXX

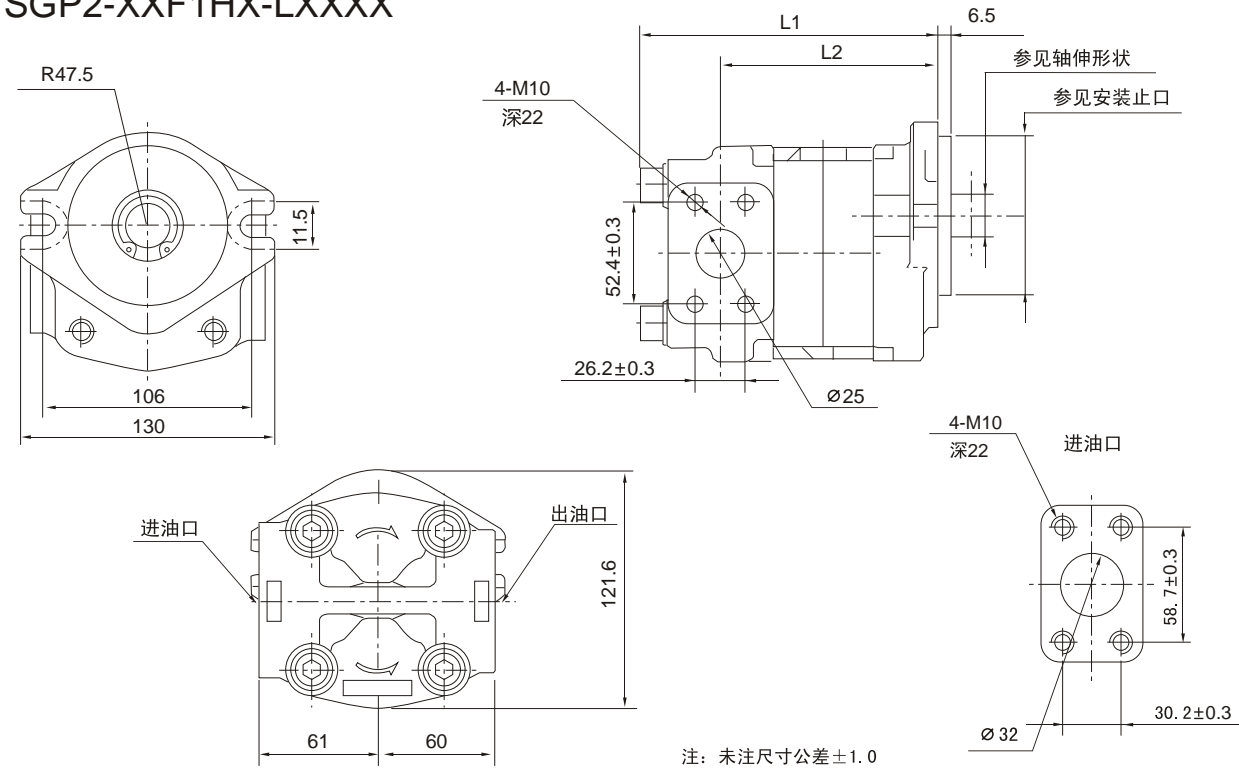

SGP2-XXA1HX-LXXXX

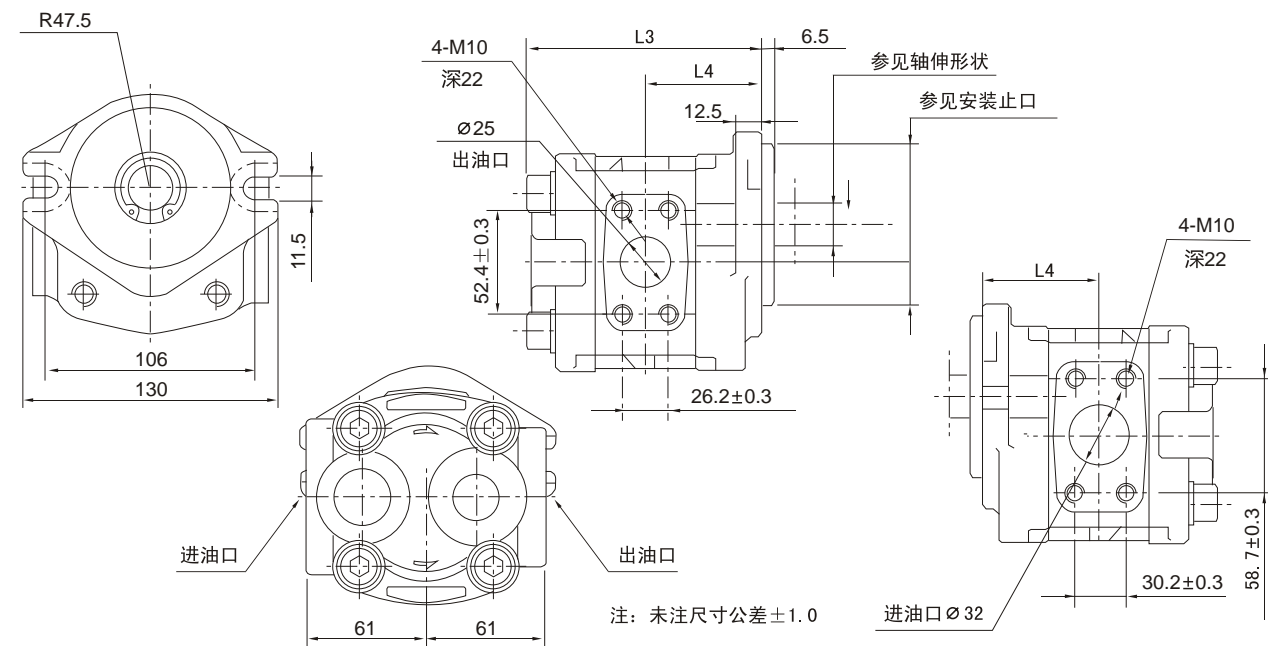

SGP2 齿轮油泵 SGP2 gear oil pumps

SGP2-XXD2HX-LXXXX

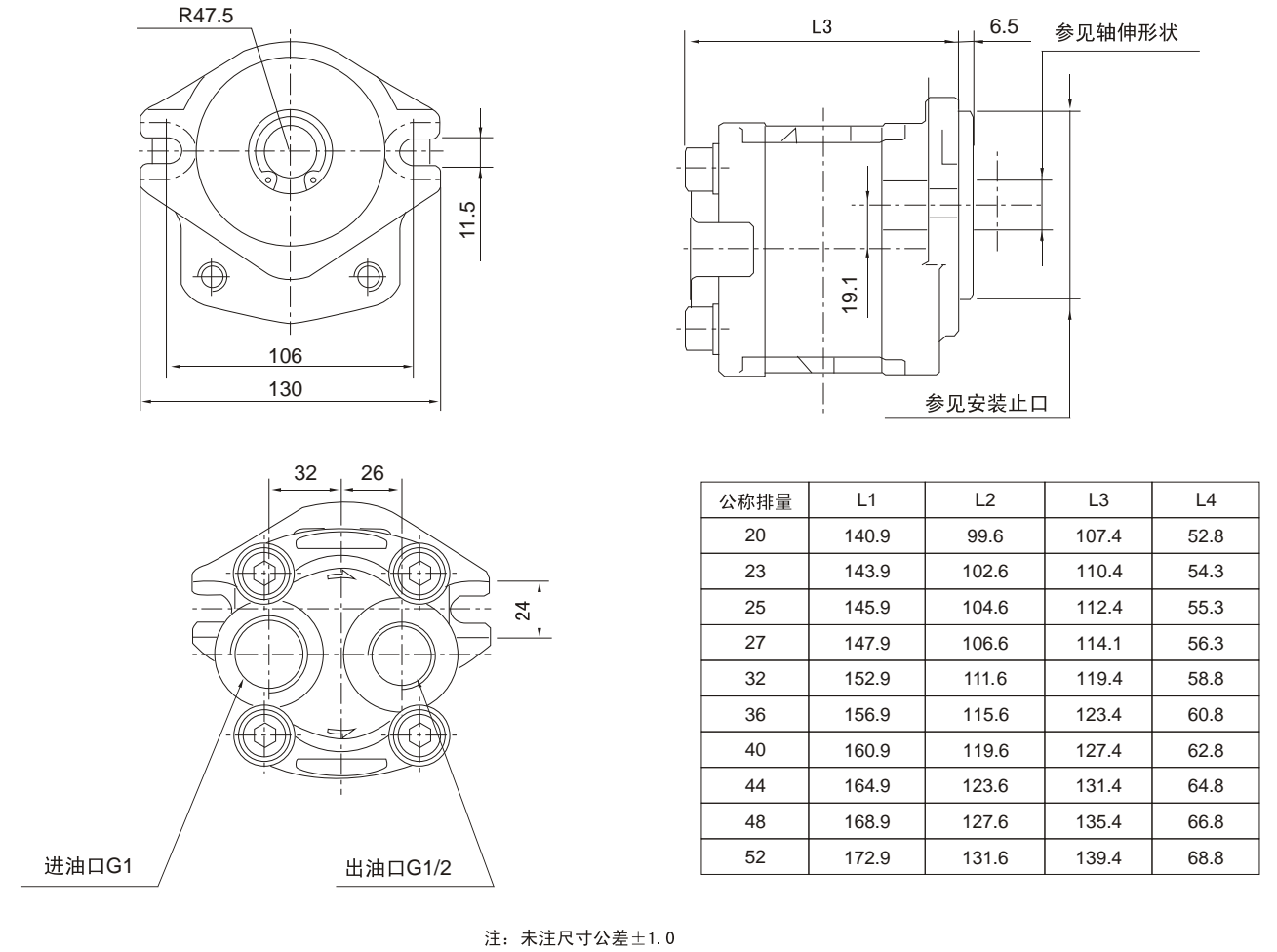

六、轴伸形状

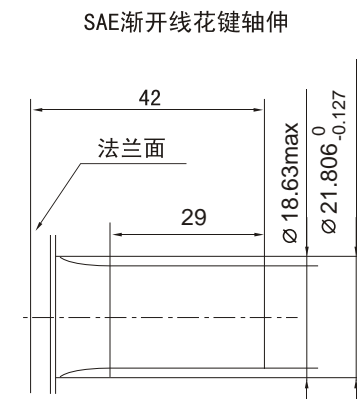

齿数	13
径节	16/32
压力角	30°
跨棒距	24.819~24.891
里棒直径	Φ3.048

进油口形状	出油口形状	油口位置		
		中间体侧面	后盖后面	后盖侧面
Φ32	Φ25	公称排量32以上	—	○
Φ25	Φ19	公称排量27~36	—	公称排量20~36
G1	G1/2	—	○	○



KZP4/KRP4系列齿轮泵 KZP4/KRP4 series gear pump

KZP4、KRP4系列齿轮油泵壳体采用高强度铝合金材料，内部结构使用了轴向间隙浮动补偿，径向平衡，DU自润滑，齿轮采用双压力等多项先进技术，它具有容积效率高，压力高，噪声低，抗震性强，寿命长等特点，广泛应用于丰田，小松叉车，装载机，挖掘机，起重机械，压路机等工程机械以及矿山，轻工，环卫，农机等行业。

KZP4, KRP4 series gear pumps adopt the material of high strength aluminum alloy and advanced technologies of axial clearance floating automatic compensation, radial balance, DU self-lubrication and gear with double pressure angles, making the pumps with the features of high volumetric efficiency, high pressure, lower noise, strong shock resistance, long lifetime, etc. The pumps are widely used in the industries of mining machinery, light industry machinery, environment sanitation machinery, agricultural machinery and he engineering machinery of forklift, loader, excavator, road roller, crane, etc.



型号说明 Model descriptions

KZP4、KRP4 — 7 A P S R B
① ② ③ ④ ⑤ ⑥

- ① KZP4、KRP4
- ② 公称排量 (毫升/转)
Nominal displacement (mL/r)
7、9、12、14、17、23、27、33
- ③ 旋转方向 (轴端看)
Direction of rotation (from shaft end)
A: 左旋 (逆时针) Left rotation (counterclockwise)
C: 右旋 (顺时针) Right rotation (clockwise)
- ④ 轴伸方式 Shaft type
P 平键 Straight spline S: SAE 花键 SAE spline
T 锥度轴 Taper shaft X: 渐开式花键 Involute spline
- ⑤ 油口形式 Port configuration
S.SAE 法兰油口
SAE flange port
进油口 Inlet: $\phi 25$; 52.4×26.2 ; 3/8-16UNC (M10*1.25)
出油口 Outlet: $\phi 18$; 47.6×22.2 ; 3/8-16UNC (M10*1.25)
D. 进油口 Inlet: SAE 法兰 SAE flange
出油口 Outlet: 7/8-14UNF
- S: SAE 螺纹油口形式
SAE screw thread port
进油口 Inlet: $1\frac{1}{16}$ -12UNC
出油口 Outlet: 7/8-14UNF
- ⑥ 油口位置 Position of ports
R 进油口在侧面 (在泵体上)
Inlet, outlet both at the side (on body)
A 进油口在泵体上, 出油口在泵盖上
Inlet on body, outlet on cover front
- ⑦ 安装方式 Mounting
B. 水平方向2个螺栓中心距 Horizontal 2 bolts: 106.2
螺栓 Bolts: M10*1.25
C. 水平方向2个螺栓中心距 Horizontal 2 bolts: 106.2
内孔 Inner bore: $\phi 11$
D. 水平方向2个螺栓中心距 Horizontal 2 bolts: 106.2
开口 Opening

性能参数 Performance parameters

型号 Models	公称排量 Nominal displacement (mL/r)	最高压力 Max Pressure (Mpa)	转速 Rotation speed (r/min)		重量 Weight (kg)
			最低 Min	最高 Max	
KZP4/KRP4-7	7.0	17.2	500	3500	2.3
KZP4/KRP4-9	9.4				2.4
KZP4/KRP4-12	11.9				2.5
KZP4/KRP4-14	14.8		500	3000	3.0
KZP4/KRP4-17	16.8		600		3.1
KZP4/KRP4-19	19.2		600		3.2
KZP4/KRP4-23	22.9	15.7	650	2500	3.3
KZP4/KRP4-27	26.5				3.4
KZP4/KRP4-33	33.3				13.7



KZP4系列齿轮泵 KZP4 series gear pump

外形图 Layout

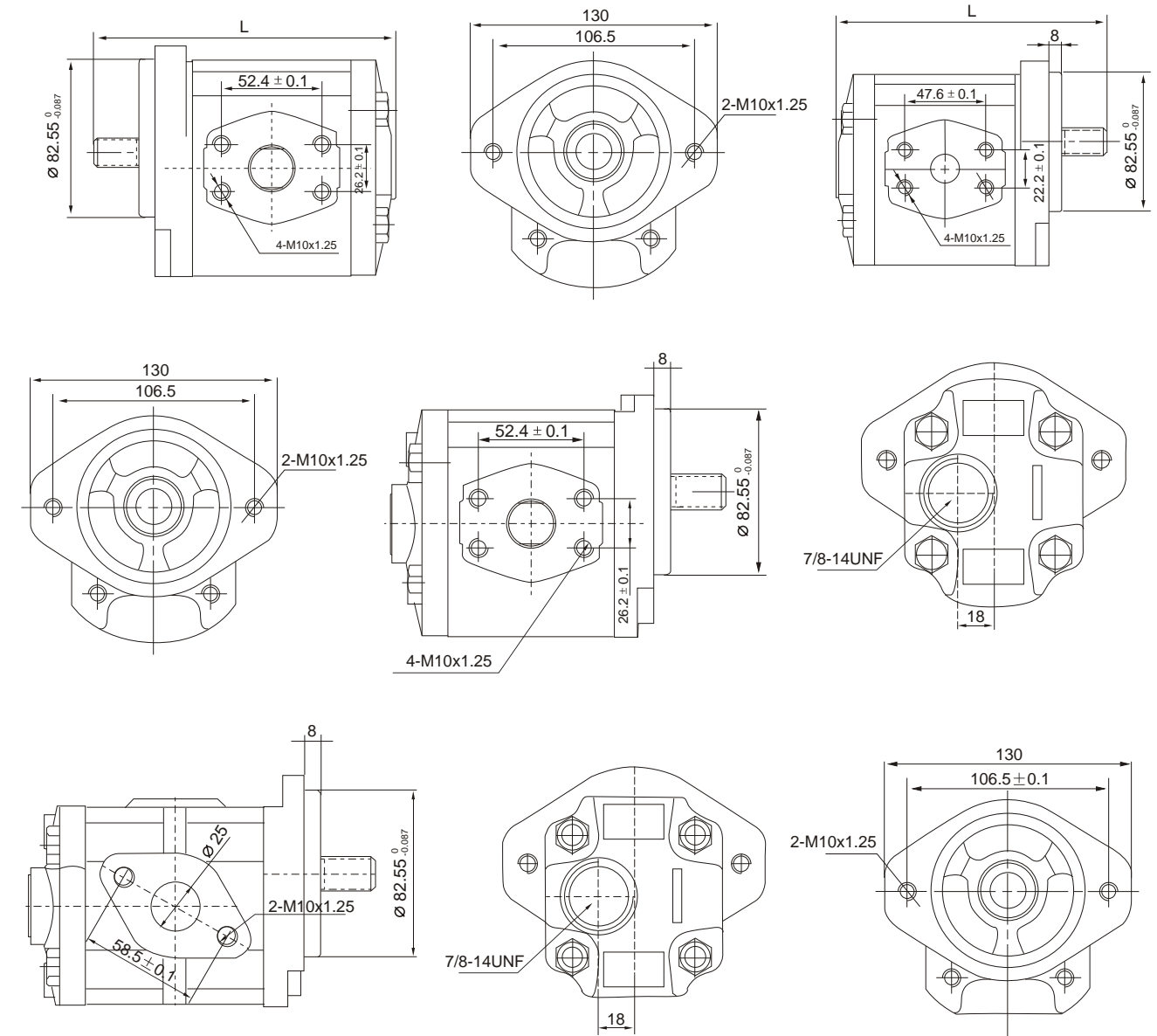

平键 Plain key

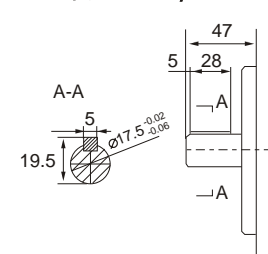

渐开线花键 Involute spline

渐开线花键 Involute spline	
齿数 Teeth No.	13
径节 D.P	16/32
压力角 Pressure angle	30°
大径 Major diameter	$\phi 17.0_{-0.13}$
小径 Minor diameter	$\phi 13.5_{-0.1}$

SAE花键 SAE spline

SAE花键 SAE spline	
齿数 Teeth No.	10
模数 Modulus	1.5
压力角 Pressure angle	30°
大径 Major diameter	$\phi 17.0_{-0.08}$
小径 Minor diameter	$\phi 13.9_{-0.1}$