

# Blince hydraulic vane pump





◎加工中心 CNC machining center



◎自动测试台 Automatic testing bench



◎定子磨 Stator grinding machine



◎数控机床 NC machines

## PV2R系列高压低噪音叶片泵 PV2R Series high pressure vane pumps with lower noise

### 产品简介

PV2R系列高压低噪音叶片泵是本公司开发的新型产品，该泵是近年在综合国内外同类产品优点基础上研发的全国产系列产品，具有结构合理、性能先进、效率高、噪声低、脉动小、可靠性好等特点。该泵规格齐全，安装连接尺寸符合国家标准和国际标准外，还有多个派生系列安装连接尺寸，可满足国内外同类产品替代要求，极大方便用户，广泛应用于机床、塑料机械、锻压机械、工程机械、交通运输机械等领域。

### Products introduction

PV2R series high pressure vane pumps with lower noise are the new developed products with the integration of the advantages of similar products at home and abroad in recent years, with the features of rational structure, high performance, high efficiency, lower noise, small pulsation, strong reliability, etc. The pumps provide extreme convenience for users and meet the substitution requirements for similar products with full specifications, national and international standard mounting dimensions, as well as derivative series mounting dimensions, making the pumps widely applied in the fields of machine tool industry, plastic machinery, forging machinery, engineering machinery, transportation machinery, etc.

### 单泵 Single Pumps

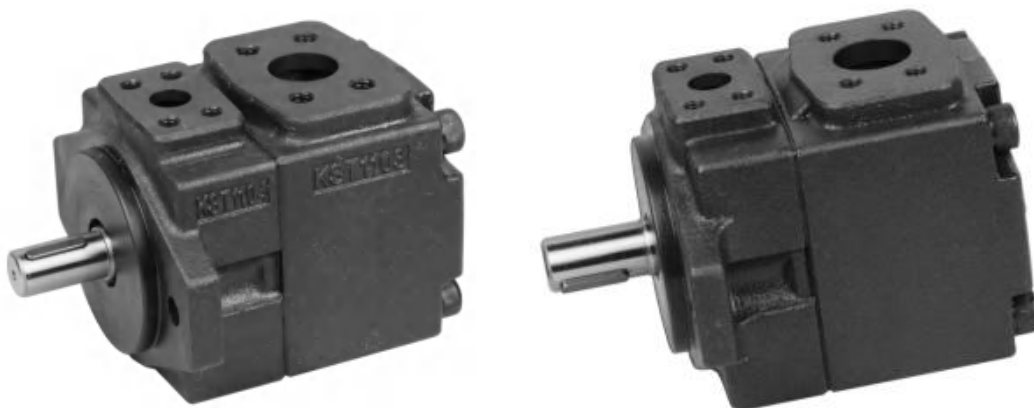

### 型号说明 Model Descriptions

PV2R1	1	-*	-F	-1	-R	-A	-A
叶片泵 产品代号 Vane pumps' codes	子系列号 Model of subsidiary series	公称排量 ml/r Nominal displacement	安装型式 Mounting type	轴伸形式 Shaft extension	旋转方向 Direction of rotation	排出口位置 Outlet position	吸入口位置 Inlet position
PV2R 1		6,8,10,12,14,17, 19,23,25,28,31	F: 法兰安装型  F: Flange mounting	1: 大轴标准 1: Major shaft standard  2: 小轴 2: Minor shaft	(从轴端看) R:顺时针方向 (右旋标准) (from shaft end) R: Clockwise direction (Right rotation standard)	(从轴端看) A:上方(标准) R、B、L (排出口A设定为上方)	(从轴端看) A:上方(标准) B:下方 R:右方 L:左方
PV2R 2		26,33,41,47, 53,59,65,75			(从轴端看) L:逆时针方向 (左旋) L:Counterclockwise direction (Left rotation)	(from shaft end) A: Upper(Standard) R、B、L (Outlet port A is set as upper.)	(from shaft end) A: Upper(Standard) B: Bottom R: Right L: Left
PV2R 3		52,60,66,76,85,94 116,125,136,153					

# PV2R系列叶片泵 PV2R series vane pumps



## PV2R系列高压低噪音叶片泵 PV2R Series high pressure vane pumps with lower noise

### 技术参数 Technical parameters

产品 型号 Model	理论排量 Theoretical displacement (mL/r)	最高使用压力 Max pressure					允许转速 Allowed driving speed (r/min)		质量 Weight (kg)
		石油系工作油 Working oil of Petroleum series			水基合成液 Water-based synthetic hydraulic fluid		最高 Max	最低 Mini	
		高压用特定油 Particular pressure oil	抗磨液压油 Anti-wear oil	普通液压油 Common oil	耐磨性水乙二醇 Anti-wear water -glyco	磷酸酯脂肪酸酯 Sul phosuccinic ester fatty of acid			
PV2R1-6 PV2R1-8 PV2R1-10 PV2R1-12 PV2R1-14 PV2R1-17 PV2R1-19 PV2R1-23 PV2R1-25 PV2R1-28 PV2R1-31	6.1 8.1 10.2 12.3 14.0 16.3 18.3 22.5 25.1 27.6 30.6	21	17.5	16	16	16	1800 (1200)	750	8
PV2R2-26 PV2R2-33 PV2R2-41 Pv2R2-47 PV2R2-53 PV2R2-59 PV2R2-65 PV2R2-75*	25.4 32.2 40.5 46.2 52.3 58.2 64.1 74.5	21	17.5	14	16	14	1800 (1200)	600	16
PV2R3-52 PV2R3-60 PV2R3-66 PV2R3-76 PV2R3-85 PV2R3-94	51.5 62.9 67.0 79.2 84.5 93.8	21	17.5	14	16	14	1800 (1200)	600	32
PV2R3-116 PV2R3-125 PV2R3-136 PV2R3-153	113.2 122.8 135.8 152.8	17.5	16		14	1200	#34		

注:

- 1、公称排量“6”、“8”泵，超过16Mpa使用时，转速不低于1450r/min。
- 2、使用水基、合成液压力时，最高转速限制在1200r/min。
- 3、对于严格要求低噪声的场合，建议工作转速在1000r/min，最高工作压力在12~14MPa。
- 4、有\*处为PV2R2-W组拓展规格，有#处为PV2R3-W组2个拓展规格，泵体加长10mm，安装尺寸相同，接受特殊订货。
- 5、驱动功率近似计算：泵的排量（mL/r）×电机转速（r/min）×工作压力（MPa）/49000。计算结果单位为KW。

Notes:

1. The rotation speed shall not be less than 1450r/min for the pumps with the nominal displacement of 6 ml/r or 8 ml/r working under the pressure exceeding 16Mpa.
2. The highest rotation speed shall be limited within 1200r/min, while applying with water-based synthetic hydraulic fluids.
3. It is recommended to work with rotation speed of 1000r/min and maximum pressure of 12-14Mpa on the occasion where lower noise is strictly required.
4. Those pumps with the marks \* belong to the extension specification of PV2R2-W group. Those pumps with the marks # belong to the extension specification of PV2R3-W group. These two groups pump casing are 10mm longer than usual specification for special order.
5. The approximate calculation formula for driving power is as follows: the displacement of pump(mL/r) × the rotation speed of motor(r/min) × the working pressure (Mpa) / 49000. The unit for the final calculation result is KW.

# PV2R系列叶片泵

## PV2R series vane pumps



### PV2R系列高压低噪音叶片泵 PV2R Series high pressure vane pumps with lower noise

#### 外型及安装连接尺寸

#### Shape and installation dimensions

法兰安装型: PV2R1- \* -F-1-RAA  
 Flange mounting: PV2R1- \* -F-1-RAA

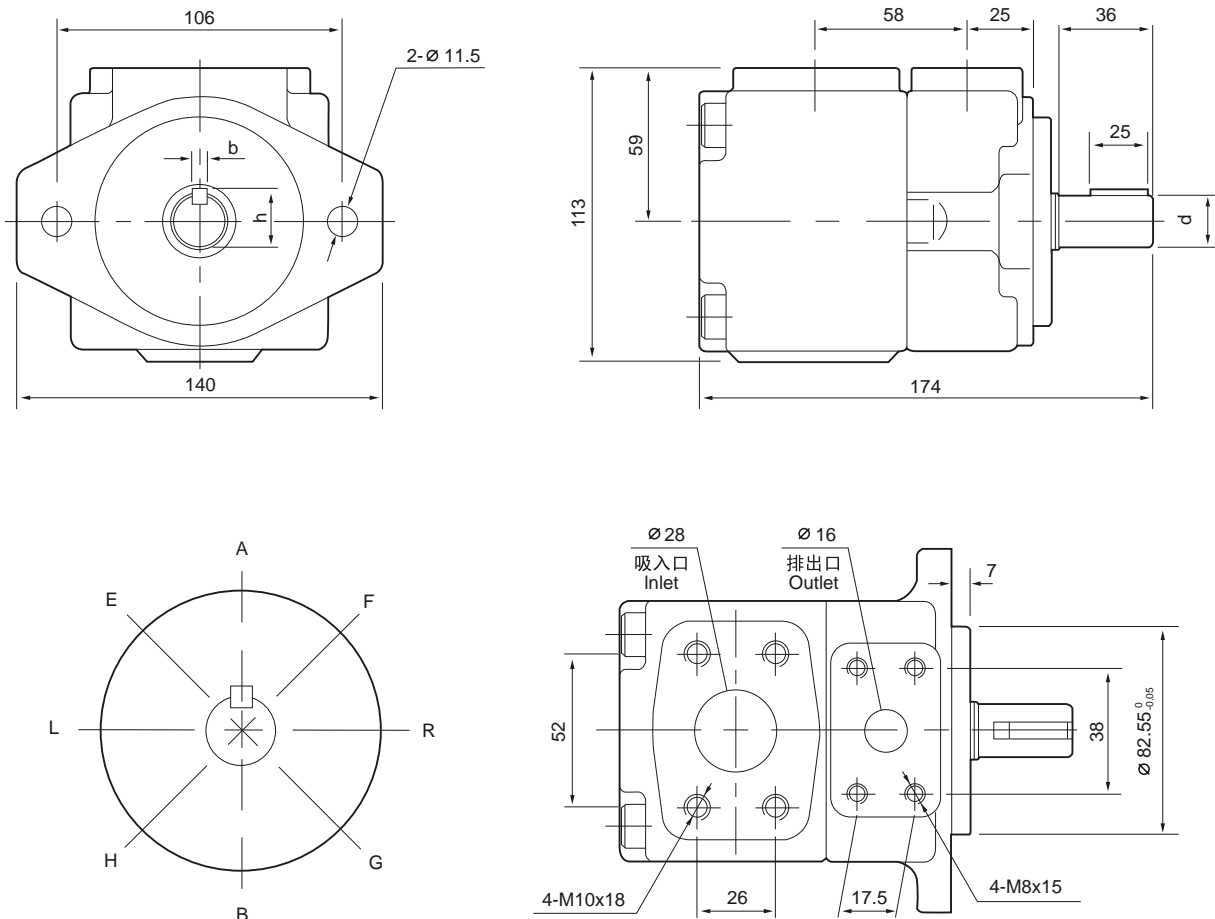

轴伸形式 Shaft extension	d	b	h	备注 Remarks
1	$\varnothing 19.05_{-0.03}^0$	$4.75_{0}^{+0.03}$	$21.24_{-0.16}^0$	大轴 Major shaft
2	$\varnothing 15.88_{-0.03}^0$	$3.97_{0}^{+0.03}$	$17.68_{-0.16}^0$	小轴 Minor shaft



# PV2R系列叶片泵

## PV2R series vane pumps



### PV2R系列高压低噪音叶片泵 PV2R Series high pressure vane pumps with lower noise

#### 外型及安装连接尺寸

#### Shape and installation dimensions

法兰安装型: PV2R2- \* -F-1-RAA

Flange mounting: PV2R2- \* -F-1-RAA

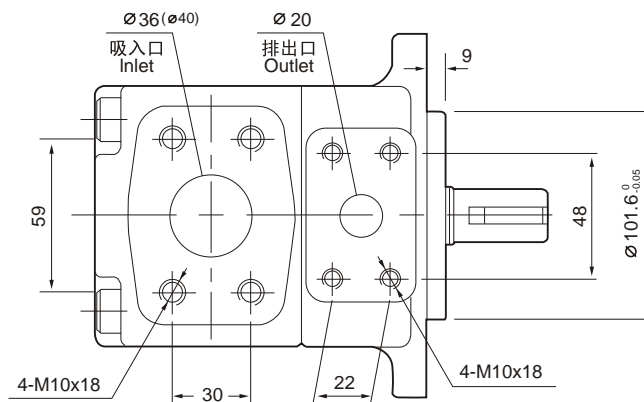
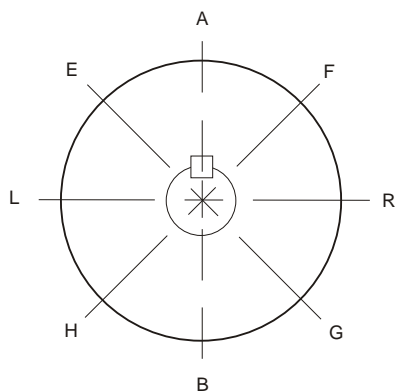
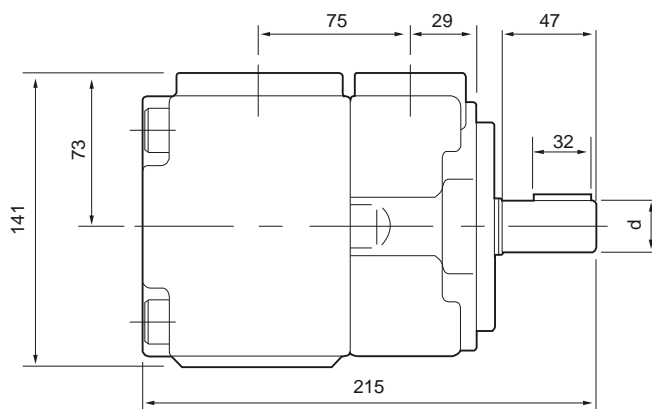
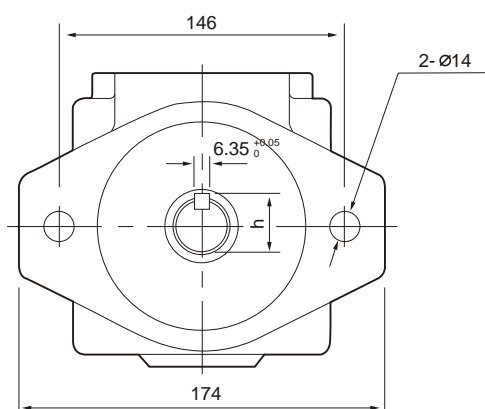

轴伸形式 Shaft extension	d	h	备注 Remarks
1	$\varnothing 25.4_{-0.05}^0$	$28.18_{-0.18}^0$	大轴 Major shaft
2	$\varnothing 22.23_{-0.03}^0$	$25.01_{-0.18}^0$	小轴 Minor shaft

**PV2R系列高压低噪音叶片泵** PV2R Series high pressure vane pumps with lower noise

**外型及安装连接尺寸**  
**Shape and installation dimensions**

法兰安装型: PV2R3- \*-F-1-RAA  
Flange mounting: PV2R3- \*-F-1-RAA

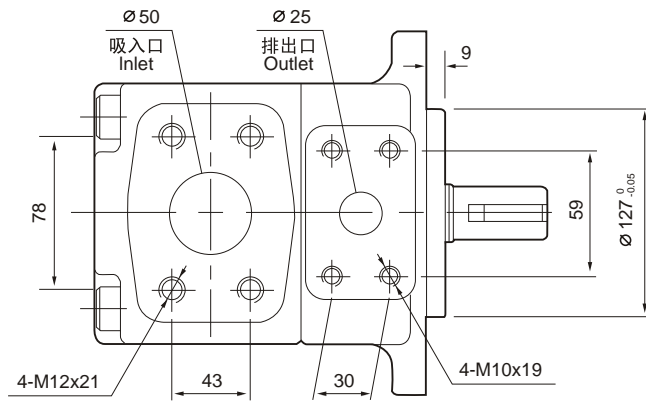
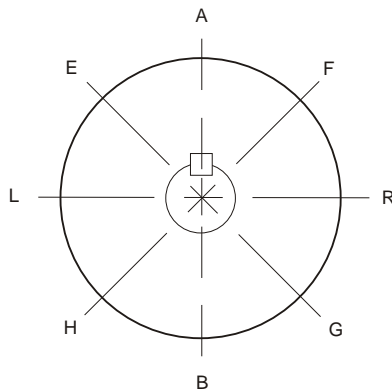
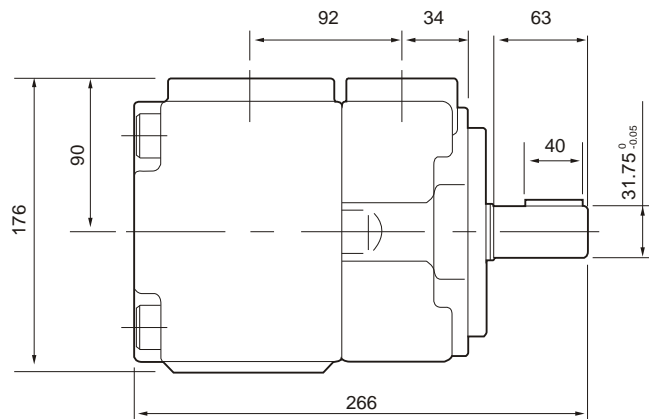
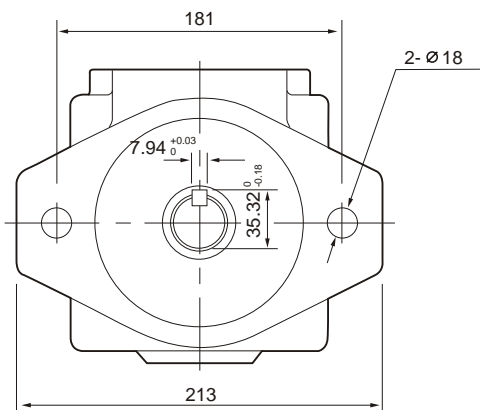

# PV2R系列叶片泵 PV2R series vane pumps



## PV2R系列高压低噪音叶片泵 PV2R Series high pressure vane pumps with lower noise

### 双联叶片泵

本系列泵由同一轴驱动的两个PV2R系列单泵；并联组装在同一壳体内而成，具有一个共用进油口和两个可以输向两个独立回路的出油口；

按照两个泵的系列组合，可获得多种流量。双泵的驱动功率为二单泵功率之和。

### Double vane pumps

The double vane pumps are composed with two single PV2R series pumps, which were driving by one shaft and were assembled in parallel in one pump casing with one common inlet port and two outlet ports that connecting to two individual oil circuits.

A variety of flows can be obtained by different combination of the two pumps. The power of double vane pumps is the power sum of two single vane pumps.

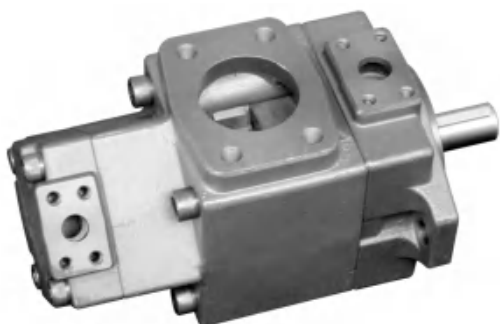

PV2R	13	-*	-*	-F	-1	-R	-A	-A	-A	
叶片泵 产品代号 Models	子系列号 Code of subsidiaries series	盖端泵 公称排量 Cover end pump displacement (mL/r)	轴端泵 公称排量 Shaft end pump displacement (mL/r)	安装型式 Mounting type	轴伸形式 Shaft extension	旋转方向 Direction of rotation	盖端泵 排出口位置 Cover end pump outlet position	轴端泵 排出口位置 Shaft end pump outlet position	吸入口位置 Inlet position	
PV2R 12		6, 8, 10, 12, 14, 17, 19, 23, 25, 28, 31	26, 33, 41, 47, 53, 59, 65, 75	F: 法兰安装型  F: Flange mounting	1:大轴标准 1: Major shaft standard  2:小轴 2: Minor shaft	(从轴端看) R:顺时针方向 (右旋标准) (from shaft end) R:Clockwise direction (Right rotation standard)	(从轴端看) E:左上方45°(标准) F:右上方45° G:右下方45° H:左下方45° (from shaft end) E: Upper left 45° (Standard) F: Upper right 45° G: Bottom right 45° H: Bottom left 45°	A:上方(标准) 轴端泵的 排出口位置 设定为上方	A:上方(标准) B:下方 R:右方 L:左方	
PV2R 13		6, 8, 10, 12, 14, 17, 19, 23, 25, 28, 31	52, 60, 66, 76, 85, 94, 116, 125, 136, 153,			L:逆时针方向 (左旋) L:Counterclockwise Direction (Left rotation)	A:上方(标准) B:下方 R:右方 L:左方 A: Upper (standard) B: Bottom R: Right L: Left			A: Upper (standard) outlet position of shaft end pump shall be set as upper
PV2R 23		26, 33, 41, 47, 53, 59, 65, 75	52, 60, 66, 76, 85, 94, 116, 125, 136, 153,							E:左上方45°(标准) F:右上方45° G:右下方45° H:左下方45° (from shaft end) E: Upper left 45° (Standard) F: Upper right 45° G: Bottom right 45° H: Bottom left 45°



PV2R系列高压低噪音叶片泵 PV2R Series high pressure vane pumps with lower noise

技术参数 Technical parameters

产品 型号 Model	油泵出口 Outlet	公称排量 Nominal displacement (ml/r)	最高使用压力 Max pressure				允许转速 Allowed driving speed (r/min)		质量 Weight (kg)	
			石油系工作油 Working oil of Petroleum series			水基合成液 Water-based synthetic hydraulic fluid		最高 Max		最低 Mini
			高压用特定油 Particular pressure oil	抗磨液压油 Anti-wear oil	普通液压油 Common oil	耐磨性水乙二醇 Anti-wear water -glyco	磷酸酯脂肪酸酯 Sul phosuccinic ester fatty of acid			
PV2R12	锥端泵 Cove end pump PV2R1	-6	21	17.5	14	16	14	1800	600	22.5
		-8								
		-10								
		-12								
		-14								
		-17								
		-19								
		-23								
		-25								
		-28								
	-31									
	轴端泵 Bearing pump PV2R2	-26	16	16	16	16	750			
		-33								
		-41								
		-47								
		-53								
		-59								
-65										

注:

- 1、使用水基、合成液液压时，最高转速限制在1200r / min。
- 2、对于严格要求低噪声的场合，建议工作转速在1000r / min，最高工作压力在12-14MPa。

Notes:

1. The highest rotation speed shall be limited within 1200r/min, while adopting water-based synthetic hydraulic fluids.
2. It is recommended to work with rotation speed of 1000r/min and maximum pressure of 12-14Mpa on the occasion where lower noise is strictly required.

# PV2R系列叶片泵

## PV2R series vane pumps



### PV2R系列高压低噪音叶片泵 PV2R Series high pressure vane pumps with lower noise

#### 技术参数 Technical parameters

产品型号 Model	油泵出口 Outlet	公称排量 Nominal displacement (ml/r)	最高使用压力 Max pressure				允许转速 Allowed driving speed (r/min)		质量 Weight (kg)	
			石油系工作油 Working oil of Petroleum series			水基合成液 Water-based synthetic hydraulic fluid		最高 Max		最低 Mini
			高压用特定油 Particular pressure oil	抗磨液压油 Anti-wear oil	普通液压油 Common oil	耐磨性水乙二醇 Anti-wear water-glyco	磷酸酯脂肪酸酯 Sul phosuccinic ester fatty of acid			
PV2R13	盖端泵 Cove end pump PV2R1	-6	21	17.5	16	16	1800	750	37.5	
		-8								
		-10								
		-12								
		-14								
		-17								
		-19								
		-23								
		-25								
		-28								
	轴端泵 Bearing pump PV2R3	-31	17.5	16	14	14	1200	600		
		-52								
		-60								
		-66								
		-76								
		-85								
		-94								
		-116								
		-125								
-136										
-153										

注:

1、使用水基、合成液液压时，最高转速限制在1200r / min。

2、对于严格要求低噪声的场合，建议工作转速在1000r / min，最高工作压力在12-14MPa。

Notes:

1. The highest rotation speed shall be limited within 1200r/min, while adopting water-based synthetic hydraulic fluids.

2. It is recommended to work with rotation speed of 1000r/min and maximum pressure of 12-14Mpa on the occasion where lower noise is strictly required.

PV2R系列高压低噪音叶片泵 PV2R Series high pressure vane pumps with lower noise

技术参数 Technical parameters

产品 型号 Model	油泵出口 Outlet	公称排量 Nominal displacement (ml/r)	最高使用压力 Max pressure					允许转速 Allowed driving speed (r/min)		质量 Weight (kg)			
			石油系工作油 Working oil of Petroleum series			水基合成液 Water-based synthetic hydraulic fluid		最高 Max	最低 Mini				
			高压用特定油 Particular pressure oil	抗磨液压油 Anti-wear oil	普通液压油 Common oil	耐磨性水乙二醇 Anti-wear water -glyco	磷酸酯脂肪酸酯 Sul phosuccinic ester fatty of acid						
PV2R23	差 端 泵 Cove end pump PV2R2	-26	21	17.5	14	16	14	1800	45				
		-33											
		-41											
		-47											
		-53											
		-59											
		-65											
	轴 端 泵 Bearing pump PV2R3	-52						17.5		16	14	14	1200
		-60											
		-66											
		-76											
		-85											
		-94											
		-116											
-125													
136													
153													

注:

- 1、使用水基、合成液液压时，最高转速限制在1200r/min。
- 2、对于严格要求低噪声的场合，建议工作转速在1000r/min，最高工作压力在12-14MPa。

Notes:

1. The highest rotation speed shall be limited within 1200r/min, while adopting water-based synthetic hydraulic fluids.
2. It is recommended to work with rotation speed of 1000r/min and maximum pressure of 12-14Mpa on the occasion where lower noise is strictly required.

# PV2R系列叶片泵

## PV2R series vane pumps



### PV2R系列高压低噪音叶片泵 PV2R Series high pressure vane pumps with lower noise

#### 外型及安装连接尺寸

#### Shape and installation dimensions

法兰安装型: PV2R12-\*/\*-F-1-REAA

Flange mounting: PV2R12-\*/\*-F-1-REAA

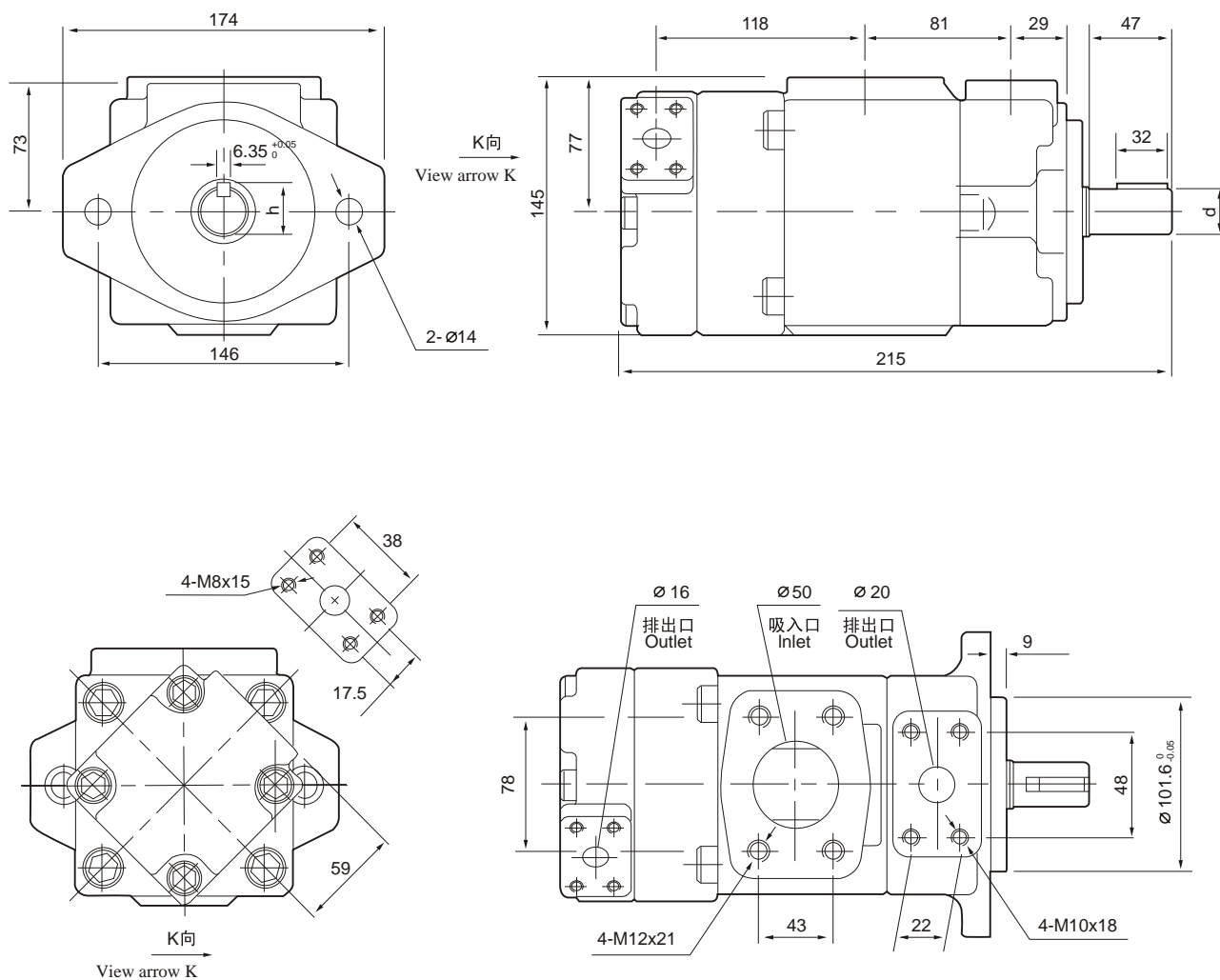

轴伸形式 Shaft extension	d	h	备注 Remarks
1	$\varnothing 25.4^{+0.05}_0$	$28.18^{+0.18}_0$	大轴 Major shaft
2	$\varnothing 22.23^{+0.03}_0$	$25.01^{+0.18}_0$	小轴 Minor shaft

PV2R系列高压低噪音叶片泵 PV2R Series high pressure vane pumps with lower noise

外型及安装连接尺寸  
Shape and installation dimensions

法兰安装型: PV2R13-\*/\*-F-1-RAAA  
Flange mounting: PV2R13-\*/\*-F-1-RAAA

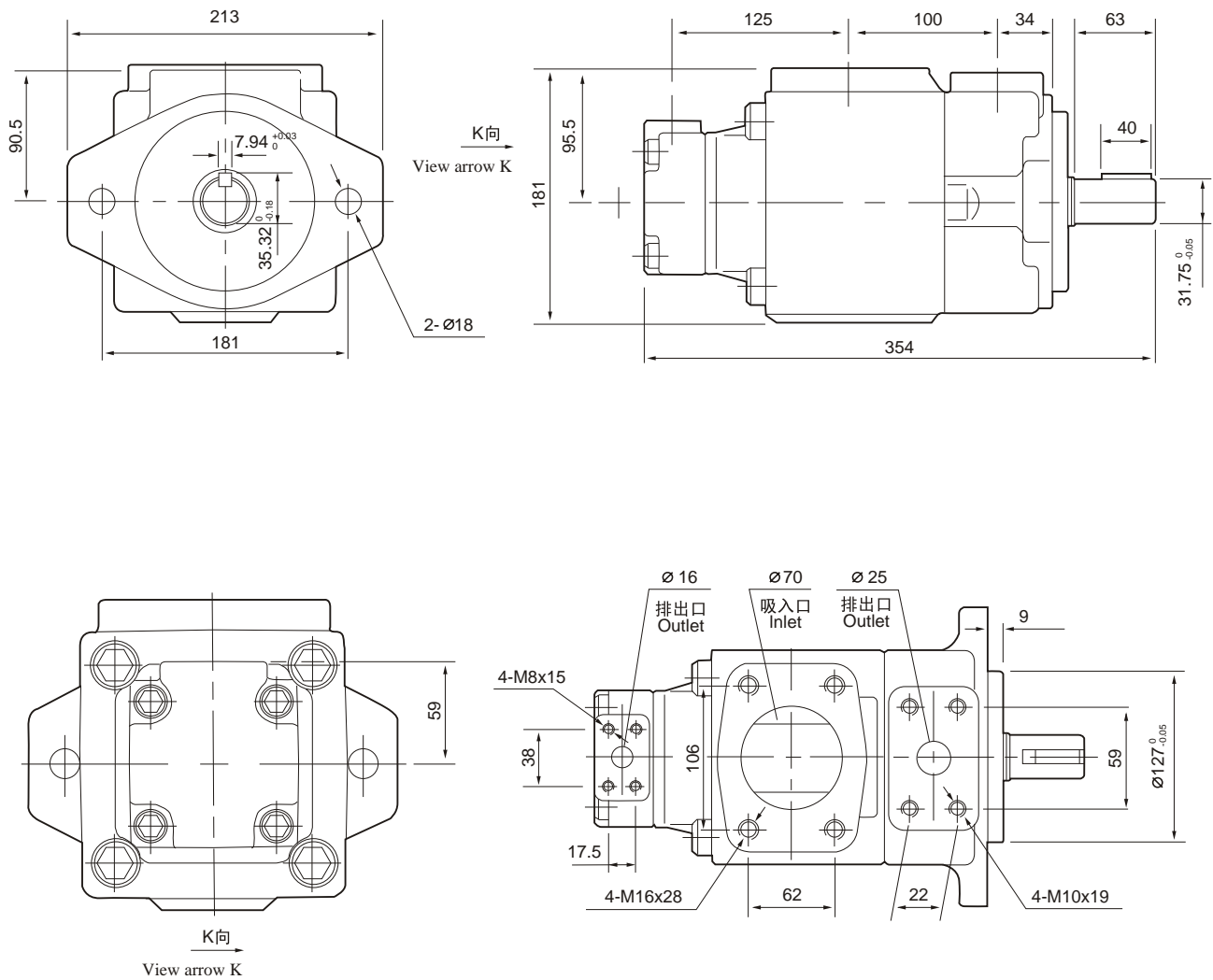

# PV2R系列叶片泵

## PV2R series vane pumps



### PV2R系列高压低噪音叶片泵 PV2R Series high pressure vane pumps with lower noise

#### 外型及安装连接尺寸

#### Shape and installation dimensions

法兰安装型: PV2R23-\*/\*-F-1-REAA

Flange mounting: PV2R23-\*/\*-F-1-REAA

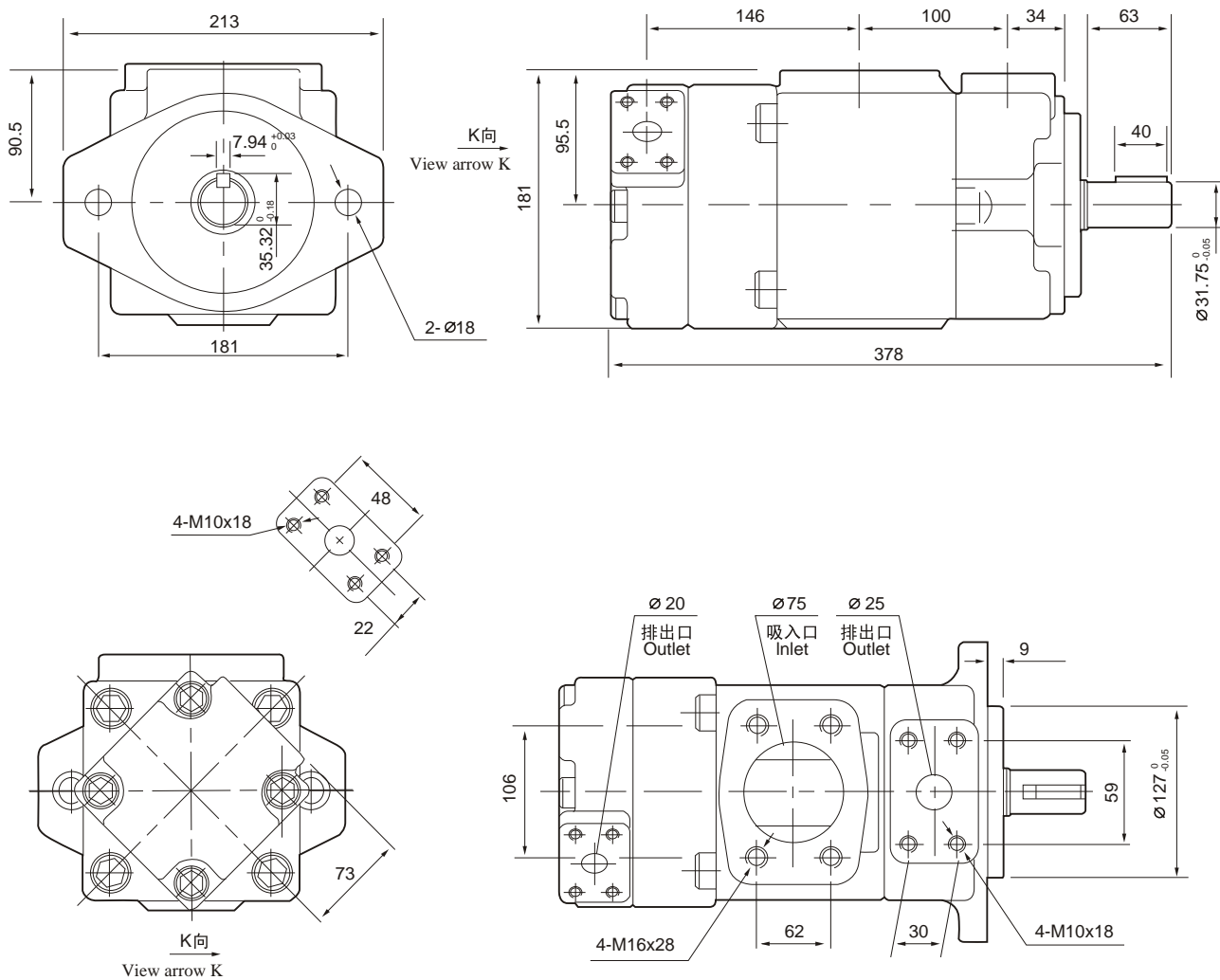



## 法兰连接组件 Flange components

### 安装连接尺寸 Installation sizes

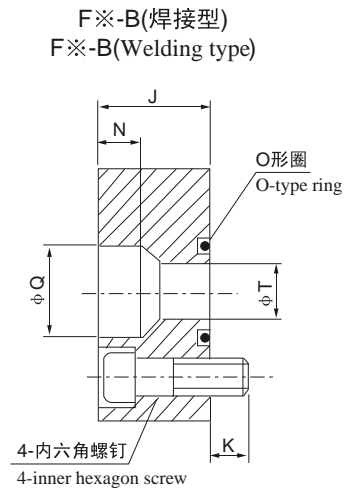
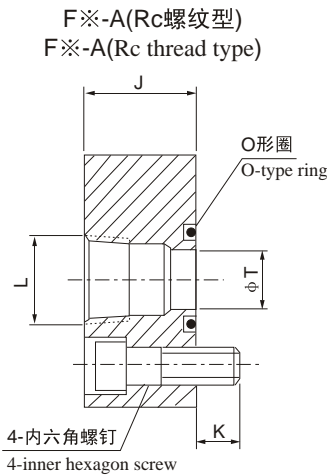
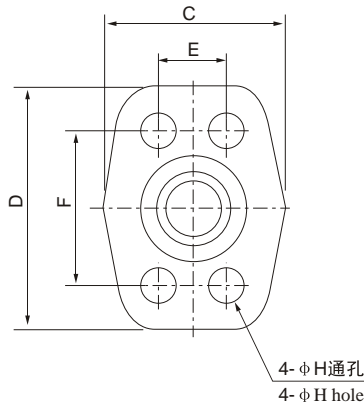

法兰型号 Flange models	对应管子规格 Corresponding pipes' specifications	尺寸 mm Sizes mm											O型圈 O-type ring GB34521-82	内六角螺钉 inner hexagon screw	螺钉拧紧力矩 Tightening torque of screw N·m	对应油泵接口 Corresponding pumps connector
		C	D	E	F	H	J	K	L	N	Q	T				
F04 A	1/2"	43	59.0	17.5	38.1	9.0	28.0	11	1/2"	—	—	13	21.2x2.65	M8x30	35	PV 2R1 出口 PV 2R12、PV 2R13 盖端泵出口 PV2R1 port PV. 2R12, PV2R13 cover end pump port
F04-B									—	11	22.5					
F06-A	3/4"	53.2	71.6	22.2	47.6	11.2	30.0	11	3/4"	—	—	19	30x3.55	M10x30	68.5	PV 2R2、PV 2R12 轴端泵出口 PV 2R23盖端泵出口 PV2R2, PV2R12 shaft end pump port PV2R23 cover end pump port
F06-B									—	12	28.5					
F08-A	1"	58.0	76.4	26.2	52.4	11.2	30.0	16	1"	—	—	26	34.5x3.55	M10x35	68.5	PV 2R1 吸入口 PV2R1 inlet
F08-B									—	14	34.5					
F10-A	1-1/4"	57.7	84.7	30.2	58.7	12.0	40.0	16	1-1/4"	—	—	32	40x3.55	M10x45	68.5	PV 2R2吸入口 PV 2R3出口、PV 2R13 PV 2R23轴端泵出口 PV2R2 inlet PV2R3 port, PV2R13, PV2R23 shaft end pump port
F10-B									—	16	43.0					
F12-A	1-1/2"	70.0	96.0	35.7	69.9	13.8	40.0	18	1-1/2"	—	—	38	50x3.55	—	118	—
F12-B									—	18	49.1					
F16-A	2"	87.0	105.0	42.9	77.8	13.8	40.0	18	2"	—	—	51	65x3.55	M12x45	118	PV 2R3、PV 2R12 吸入口 PV2R3, PV2R12 inlet
F16-B									—	20	61.0					
F20-A	2-1/2"	96.0	116.0	50.8	88.9	13.8	45.0	18	2-1/2"	—	—	63	75x3.55	—	118	—
F20-B									—	22	77.1					
F24-A	3"	121.0	141.4	61.9	106.4	17.0	45.0	17	3"	—	—	76	85x3.55	M16x45	287	PV 2R13、PV 2R23 吸入口 PV2R13, PV2R23 inlet
F24-B									—	25	90.0					
F28-A	3-1/2"	136.0	155.0	69.9	120.7	17.0	50.0	17	3-1/2"	—	—	89	100x3.5	M16x40 M16x50	287	—
F28-B									—	28	102.8					
F32-A	4"	145.0	162.0	77.8	130.2	17.0	50.0	17	4"	—	—	102	115x3.5	M16x40 M16x50	287	—
F32-B									—	28	115.5					